

Kill switch for WheeStat potentiostats

Jack Summers, PhD

summers@wcu.edu

Smoky Mountain Scientific
4989 Tilley Creek Road
Cullowhee, NC 28723

Department of Chemistry and Physics
Western Carolina University
Cullowhee, NC 28723

Abstract: This manuscript documents a modification to hardware and software for the WheeStat potentiostat that is used to cut off current between experiments. Beginning with model 7.2, all WheeStats sold will incorporate built in kill switch hardware, as described in Figure 2A. Model 7 hardware sold after June 2017 have incorporated the after-market kill switch described in Figure 2B. Model 5 hardware (with green circuit boards) and Model 7 hardware purchased before June 2017 can be modified by following the instructions provided herein.

Background: This section is for those who want a theoretical understanding of the circuit and is not

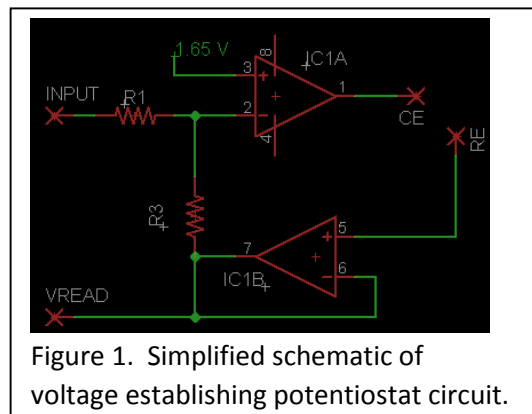

Figure 1. Simplified schematic of voltage establishing potentiostat circuit.

required for its installation and use. To understand what is going on, we first consider a simplified representation of the circuit that is used to establish voltages at the reference electrode. The schematic, presented in Figure 1, shows an input voltage on the top left that is fed to the inverting pin on amplifier IC1A. The non-inverting pin for this amp is held at 1.65 volts (half way between ground and the +3.30 volt logic level of the microcontroller we use) and the output is connected to the Counter Electrode (CE) lead. The reference electrode lead (RE, top right in Figure 1) is connected to the non-inverting pin on amplifier IC1B and the inverting and output pins for this

amp are tied together, along with the voltage reading pin of the microcontroller. This system efficiently ties the voltage of the reference electrode to the input voltage by feedback as long as the reference and

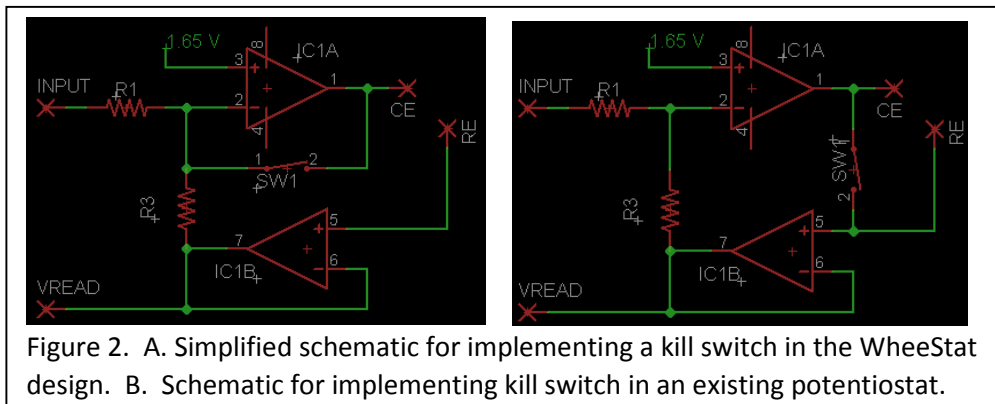

Figure 2. A. Simplified schematic for implementing a kill switch in the WheeStat design. B. Schematic for implementing kill switch in an existing potentiostat.

counter electrodes have some electrically conducting pathway between them (such as the migration of ions in the cell or some redox process that affects the measured voltage at RE). A problem occurs when one of the electrodes is removed from the cell. In this situation, the feedback loop is broken and the voltage at the counter electrode lead will most likely spike to one of its possible extremes. To mitigate this issue, we have developed two strategies for implementing a kill switch that sets the voltage at the counter electrode equal to that at the working electrode (WE is not represented in Figures 1 or 2, but is held at 1.65 volts). These two strategies are represented in Figures 2A and 2B.

The circuit in Figure 2A differs from that in Figure 1 by the inclusion of a switch (SW1) between the output and inverting input terminal of IC1A. If the switch is closed between experiments, then the voltage at the counter electrode is fed back to the inverting terminal. Under this condition, the voltage at CE is equal to that of the non-inverting pin, +1.65 volts, which is also the voltage at the working electrode. When the voltages of the working and counter electrodes are equal, no current passes.

Figure 2B shows a similar strategy, but where the switch bridges the counter and reference electrodes. When the switch in Figure 2B is closed, the voltage at the CE is given by Equation 1:

$$V(\text{CE}) = 1.65 + (R2/R1)(1.65 - V(\text{Input})) \quad (1)$$

While this is not as neat as the case in Figure 2A, setting the input voltage to 1.65V between experiments eliminates the second term in Equation 1, leading to $V(\text{CE}) = 1.65$ volts. Under this condition, no current passes.

Both of these strategies require incorporation of an electronically controlled switch into the hardware. We have explored the use of solid state relays and have found the IXYS model CPC1017NTR relay to be acceptable for this purpose. A large number of solid state relays and switches are available. We chose the model we did based on its 'normally open' operating mode and relatively low resistance (16 ohm maximum) when closed. It is also nice that it is big enough to manipulate with tweezers. We caution the reader to pay attention to the pin configuration diagrams in the product data sheets when choosing a relay since some (like the CPC1002N) have polarized load pins and are not appropriate for cases like this, where the voltage across the load pins may be either positive or negative. The relay uses current through an internal photodiode to switch a pair of internal transistors.

Incorporating the kill switch into existing hardware. The kill switch circuit board (Figure 3) can be purchased from OSH Park. Go to https://oshpark.com/shared_projects and search for

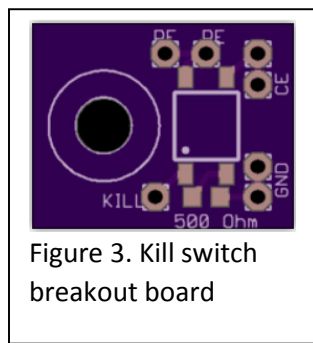

Figure 3. Kill switch breakout board

killSwitch2Gerbers by SmokyMtSci, shared Aug 16, 2017 at 15:55. The circuit uses 500 ohm chip resistor (603 package) and solid state relay (IXYS-CPC1017NTR). These are big enough to handle with tweezers and solder using a soldering iron. Solder the resistor to the pads at the bottom of the board first. The way I do this is to put a bead of solder on the right hand pad (since I am right handed) before I pick up the resistor. Using a pair of tweezers, I hold the resistor against the solder bead with my left hand and heat both the bead and resistor with the soldering iron until the solder melts. Once the solder is molten, I remove the soldering iron and continue holding the resistor in place until the solder hardens. Once the solder is

hard, the resistor will stay in place while you solder the other end. I use a similar strategy to solder the four pins of the relay, soldering the top right pin before going around to the rest. Be sure to orient the relay correctly on the board. There is a little divot on the corner beside the #1 pin. That divot should be on the lower left corner, above the white dot shown in Figure 3. The board has seven wire pads. Cut the red CE wire about 15 mm from the circuit board and solder each end to one of wire pads on upper right

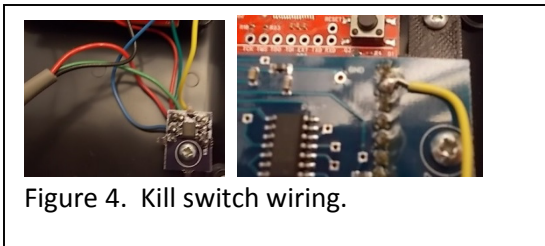

Figure 4. Kill switch wiring.

labelled CE (it does not matter which one goes to which pad). Cut green WE wire and solder each side to one of wire pads on upper left labelled RE. Solder a jumper wire from one of the GND pads (lower right) to one of the grounded pads on lower edge of red LaunchPad board. Solder another jumper wire to KILL pad on lower left and connect to PB_2 pin by either stripping and inserting to bottom side female header on Launchpad or

solder to top side of pin connection on blue WheeStat board (as shown in the right hand panel in Figure 4). In this figure the yellow wire connects the KILL pin on the purple board (lower left in Figure 3) to the PB_2 pin on the blue board (second from the top right, as shown in Figure 4). We recommend securing the boards to the case as shown in Figure 4 before soldering the yellow wire to the purple board.

To use with kill switch hardware, you will need to flash new firmware onto your WheeStat. Download the appropriate firmware from our GitHub site (https://github.com/SmokyMountainScientific/D_SeriesWheeStatFirmware) and open it up using the program Energia. Energia can be downloaded for free from www.Energia.nu. Open the “open circuit” tab and comment out lines 5-26. Then delete the “/*” and “*/” on lines 26 and 33 to un-comment lines 27 through 32. To compile and load the firmware, you will need to download the AltSPI library for Energia and install the included files in a folder called libraries in your Energia sketchbook.